



KGS-810F



Web Smart 8-Port L2 Gigabit Ethernet Switch with 1 GbE SFP Port

Product Highlights:

- 802.1Q Tagged VLAN
- QoS WFQ support
- LACP link aggregation
- 802.1x access control
- 802.1w RSTP, STP, MSTP
- DHCP client
- SFP DDM support
- Port mirroring

DIN-Rail Mounting Bracket
KC-4DR



Panel Mounting Bracket
PMB-810



Key Features:

- Provides 8 10/100/1000Mbps RJ-45 and 1 Mini-GBIC SFP slot
- Provides in-band web and SNMP management interfaces
- All copper ports support auto-negotiation and auto-MDI/MDI-X detection
- Provides full wire speed forwarding
- Supports 802.3x flow control for full-duplex and backpressure for half-duplex
- Provides port status, statistic monitoring and control function
- Supports port-based and 802.1Q Tag-based VLAN
- Provides QoS function
- Provides port link aggregation (trunking) function and LACP support
- Provides port mirroring function
- Provides 802.1x authentication for port access
- Supports 802.1w RSTP, 8021D STP and MSTP
- Watchdog timer function
- Supports SFP with Digital Diagnostic Monitoring (DDM)
- Supports DHCP for dynamic IP configuration

Specifications:

Standard	IEEE 802.3, 802.3ab, 802.3z, 802.3x, 802.1x, 802.1w, 802.1D, 802.1Q
Network Ports	7 10/100/1000Mbps Gigabit copper ports 1 combo port -10/100/1000Mbps copper & mini-GBIC SFP
Copper Port	Shielded RJ-45, 10/100/1000Mbps, auto-negotiation, auto-MDI/MDI-X support
Mini-GBIC SFP	Gigabit Ethernet 1000Base-X compliant SFP connector
Network Cables	10/100/1000Mbps copper: Cat.5 up to 100m 1000Base-X: 62.5/125µm, 50/125µm MM fiber, 9/125µm SM fiber
MAC Addresses	Table with 8K entries
VLAN Function	Port based VLAN, 8021Q Tag-based VLAN
Port Link Aggregation	Static trunking groups: 2 max., Ports/group: 2, LACP link aggregation
QoS Function	4 priority queues, Classification: Port-based, 802.1p, IP DSCP
LED Indication	Per unit: Power, management status Per port: 1000M, 100M, 10M speed/link/activity status
Web Management	Web browser software System settings, port status/statistics, port control, VLAN, QoS, Link aggregation, port mirroring, Firmware upgrade 802.1x, 802.1w, Configuration backup and restore
SNMP Support	SNMP v1, v2c management MIB-II, Event traps
DC Power Input	DC jack: -D 6.3mm/+D 2.0mm Operating voltage range: +5 ~ +12VDC (+/-5%) Power Consumption: 7.3W max.



Housing	Enclosed metal with no fan
Dimension	180 x 114 x 26 mm (WxDxH)
Mounting Support	Desktop, DIN-Rail, Panel Mounting (optional)
Environment	Operating Temperature: -5°C ~ 50°C, Storage Temperature: -20°C ~ 85°C, Relative Humidity: 10% ~ 90% non-condensing
Approval	FCC Class A, CE mark Class A

Optional Accessories:

- DIN-Rail mounting bracket
- Panel mounting bracket
- KTI quality SFP transceivers

Applications:

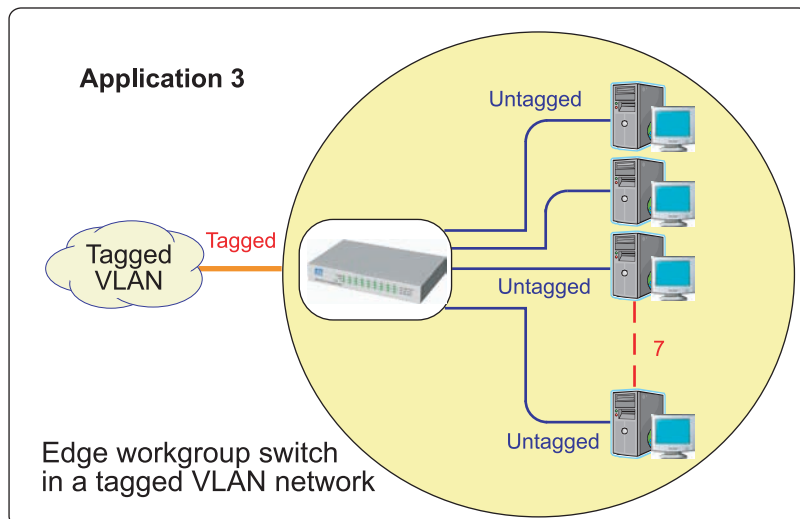
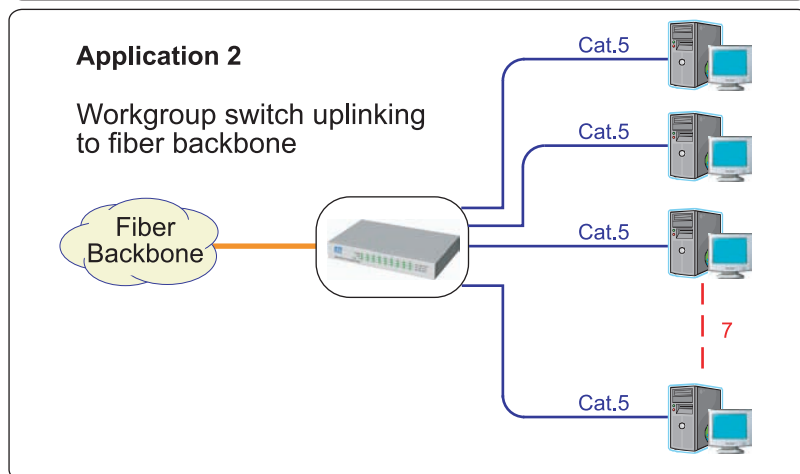
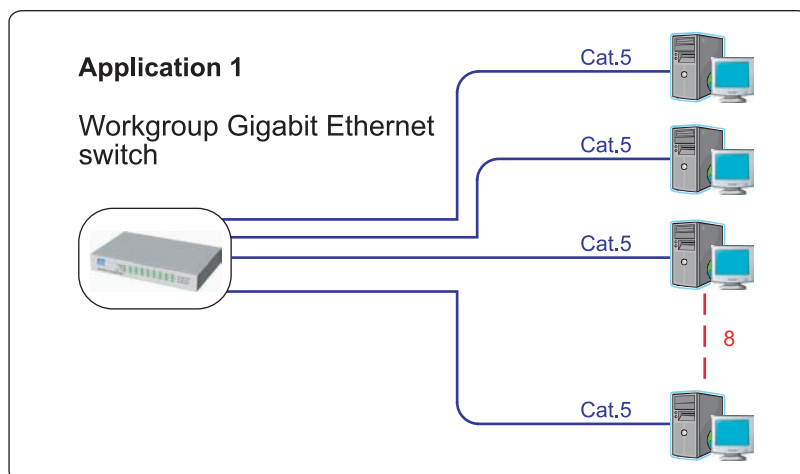

FCC Part 15, Class A
CISPR 22 Class A

Katron Technologies Inc.

15F-7, No. 79, Sec. 1, Hsin Tai Wu Rd.,
Hsi-chih District, New Taipei City, Taiwan
Tel: 886-2-2698-3878
Fax: 886-2-2698-3873
E-mail: kti@ktinet.com.tw
URL: http://www.ktinet.com.tw

KTI Networks Inc.

10415-A Westpark Drive, Houston,
TX 77042. U.S.A.
Tel: 1-713-266-3891
Fax: 1-713-914-0555
E-mail: contact@ktinet.com
URL: http://www.ktinet.com

Trademarks: All brand names are trademarks or registered trademarks of their respective holders. This information is subject to change without prior notice.